

A hand is shown pointing towards the left side of the frame, where a portion of a modern espresso machine is visible. The machine has a dark, possibly black or dark grey, finish with prominent red accents, including a vertical light strip and a glowing red base. The background is dark, making the machine and the hand stand out.

S30

Perfect Touch

LA **CIMBALI**

www.cimbali.com

WELCOME TO THE REVOLUTION TOUCH

The new super-automatic **La Cimbali** offers an unparalleled experience and, thanks to its distinctive features, it encourages innovative interaction with the machine.

The endless customisation possibilities available through the revolutionary **Touch Screen** with a 10.4" inch display and the incredible variety of drinks make the S30 revolutionary in the world of super-automatic machines.



S30

Perfect Touch





S30
Perfect Touch

LA CIBALI



RELIABILITY ABOVE ALL

The new S30 is the ideal tool for your daily tasks. Thanks to the innovative technical solutions that have always made the **La Cimbali** machines cutting-edge products, preparing espresso coffee-based drinks will be simple and intuitive, every day.

THE MOST FLEXIBLE AND CUSTOMISABLE INTERFACE

S30 has a 10.4" touchscreen display: different ways of viewing the drinks selection, customisable images on the machine display (screen savers, during beverage delivery) and films and sounds to help the customer chose their drink are some of the features offered by the S30. All while being simple and intuitive.







QUALITY IN THE CUP AND A WIDE RANGE OF DRINKS

La Cimbali knows how important each drink prepared for you and your customers is. For this reason, the S30 is designed for a wide and varied range of beverages to suit every taste, always guaranteeing the best quality in the cup.





LA CIMBALI



WHAT YOU NEED
FOR A
PERFECT DAY





Capacitive Touch Screen Display

- ✓ Toughened glass.
- ✓ Capacitive Touch Screen Panel with 10.4" TFT.
- ✓ Backlit RGB panel.
- ✓ RGB lights on the delivery area.
- ✓ Possibility to add customised images for drinks, films and screen saver using a USB stick.
- ✓ Bidirectional Wi-Fi as standard.



New Grinders with PGS function

The first step to perfection is the quality in the cup of an excellent coffee. The Titanium S30 grinders - steel with PVD - are very robust and built to last. Another innovation is the PGS (Perfect Grinding System), which continuously monitors the coffee delivery parameters and automatically re-grinds and doses if necessary, so as to ensure consistency in delivery and optimal extraction quality.

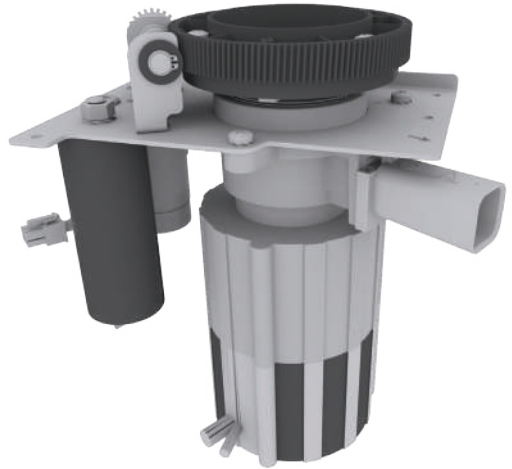

HQ Cold and Hot Frothed Milk

The new S30 can prepare both hot or cold frothed milk (Snowmilk), thus expanding the menu with recipes made with coffee, hot chocolate, cold and hot frothed milk. With S30 you can savour hot and cold frothed milk like it was prepared by an expert hand: a unique experience!



Turbo Steam Cold Touch

The new TURBOSTEAM COLD TOUCH (TS CT) steam wand has an outer surface covered by a specific insulating and non-stick material that keeps it cold before, during and after the delivery of steam. This solution guarantees ease in cleaning by avoiding the presence of milk residues after use.

New Services Boiler and Coffee Heater

S30 is equipped with two boilers, made from stainless steel with external insulation: the first generates steam and hot water, while the other is dedicated to the preparation of coffee-based beverages.

The new coffee boiler preforms better and allows for more consistency in the delivery of Coffee Cream, Americanos etc. The patented Smart Boiler system optimises the performance of hot water and steam avoiding reduced production during rush hours.



Hoppers and Solubles

Double hopper for coffee from 1 to 1.2 kg and an incorporated soluble hot chocolate system. The S30 ensures the optimal delivery of soluble materials.

Motorised Spout (Optional)

The motorised control of the supply spout allows you to set the different positions of the spout for each programmed drink.





Integrated Bidirectional Wi-Fi system

You can communicate with the S30 remotely thanks to the integrated bidirectional Wi-Fi, making it quick and easy to upgrade the software, adjust the recipes and personalise the interface images.

AWS Automatic Washing System

The daily wash cycles are managed automatically by the AWS. This innovative system cleans deeply and efficiently, ensuring maximum hygiene at the touch of a button.





S30
Perfect Touch

LA CIMBALI

A journey through Espresso





LA CIMBALI

coffee starts here

COFFEE STARTS HERE: a journey that sets out from Milan and reaches markets worldwide, with roots that spring from the power of industrial design. La Cimbali: more than just espresso, with a varied range of beverages supplied every day, ready to satisfy international tastes and trends.



Cup-warmer

Width / Breite (mm/in)	290 / 11.4
Depth / Tiefe (mm/in)	435 / 17.1
Max Height / Max. Höhe (mm/in)	738 / 29



Fridge module 4 lit

Width / Breite (mm/in)	290 / 11.4
Depth / Tiefe (mm/in)	435 / 17.1
Max Height / Max. Höhe (mm/in)	738 / 29



Fridge module 8 litri

Width / Breite (mm/in)	290 / 11.4
Depth / Tiefe (mm/in)	435 / 17.1
Max Height / Max. Höhe (mm/in)	643 / 25.3

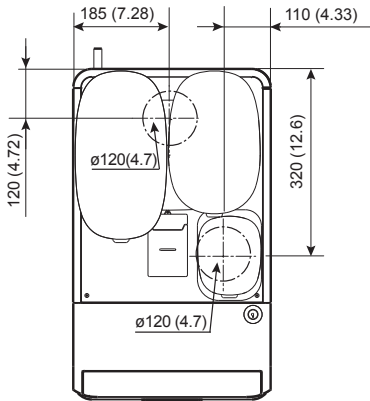
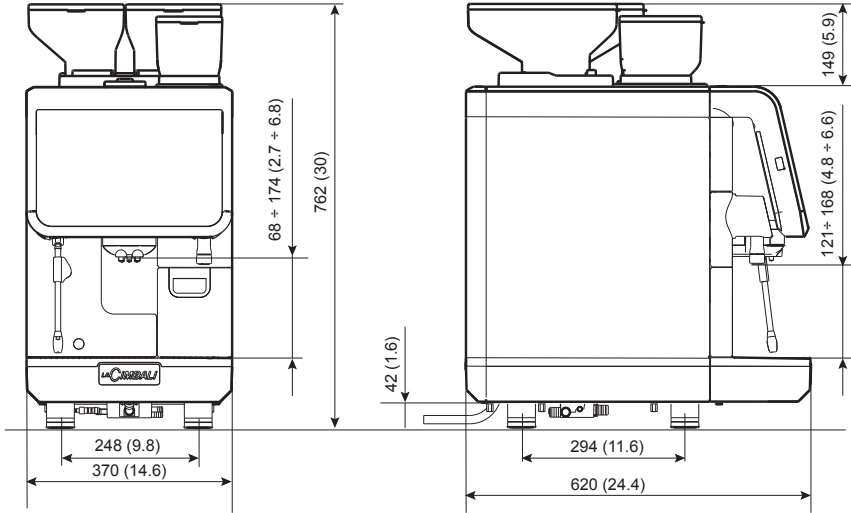

TECHNICAL DATA

	S + TS	CP	CP + TS	CS
Dose selection keys	24 12 x 2 8 x 3 4 x 6	24 12 x 2 8 x 3 4 x 6	24 1	24 12 x 2 8 x 3 4 x 6
Hot water selections	2	2	2	2
Hot water wand	1	1	1	1
Water by-pass	✓	✓	✓	✓
Steam wand	-	1	-	1
Turbo Steam Cold Touch	1	-	1	-
MilkPS	-	1	1	1
Snowmilk	-	✓	✓	✓
Smart Boiler	✓	✓	✓	✓
PGS	✓	✓	✓	✓
Boiler	2	2	2	2
Boiler capacity	0,7 L	0,7 L	0,7 L	0,7 L
Hot water and steam boiler capacity	1,25 L	1,25 L	1,25 L	1,25 L
Coffee dosing grinders	2	2	2	2
Coffee bean hoppers	2	2	2	2
Coffee bean hopper capacity	2 x 1,2 Kg	2 x 1,2 Kg	2 x 1,2 Kg	1 x 1,2 Kg + 1 x 1,0 Kg
Solubles hopper	-	-	-	1
Solubles hopper capacity	-	-	-	1,0 Kg
Solubles mixer	-	-	-	1
Bidirectional Wi-Fi	✓	✓	✓	✓
USB	✓	✓	✓	✓

DIMENSIONS

Dimensions L x D x H (mm/inch)			370 x 620 x 762
Weight (kg)			79
Installed power at	220-240V 50Hz 220V 60Hz	(w)	4800 - 5700 4800
	380-415V3N 50Hz 380V3N 60Hz	(w)	4800 - 5700 4800
	220-240V 50Hz @ 16 AMP 220V 60Hz	(w)	3300 - 3800 3400

OPTIONAL

Motorised spout	✓	✓	✓	✓
Microfilter	✓	✓	✓	✓
Direct emptying	✓	✓	✓	✓



S30

Perfect Touch



PUBLICIMBALI 16-459

Gruppo Cimbali S.p.A.
Via Manzoni, 17
20082 Binasco (MI)
Italy
Tel. +39 02 90 04 91



LA **CIMBALI**

www.cimbali.com